

Clarke®



MECHANICS MOBILE SEAT MODEL NO: CMS3

PART NO: 7630228

USER INSTRUCTIONS

GC 04/26 - rev 1

INTRODUCTION

Thank you for purchasing this CLARKE Mechanics Mobile Seat.

Before attempting to use the product, it is essential that you read this manual thoroughly and carefully follow all instructions given. In doing so you will ensure the safety of yourself and that of others around you and you can also look forward to the product giving you long and satisfactory service.

GUARANTEE

This CLARKE product is guaranteed against faulty manufacture for a period of 12 months from the date of purchase. Please keep your receipt as proof of purchase.

This guarantee is invalid if the product is found to have been abused or tampered with in any way, or not used for its intended purpose.

Faulty goods should be returned to their place of purchase, no product can be returned to us without prior permission. This guarantee does not effect your statutory rights.

SAFETY PRECAUTIONS

1. Use your mobile seat for any task where you would normally sit or kneel, ensuring the floor surface is hard enough that the castors do not sink in.
2. **DO NOT** leave the mobile seat where it may be accidentally trodden on.
3. Have any damaged parts repaired or replaced immediately. Use genuine Clarke parts only. The use of unauthorised parts may be dangerous and will invalidate the guarantee.
4. **NEVER** climb on, stand on, or attempt to ride on the mobile seat or use it to transport heavy objects.

UNPACKING & ASSEMBLY

Unpack and lay out all components, checking for any damage which may have occurred during transit, and ensuring that all parts are accounted for by checking against the parts list. Should there be any deficiency or damage, please contact your CLARKE dealer immediately.

- Using the hand tools supplied, assemble as follows.
- Mount the side supports (2) to the base assembly with the 14mm bolts (11), small washers (10), spring washers (5) and domed nuts (4), tightening securely.
- Attach the seat cushion (1) to the side supports, using the x-headed machine screws (3).

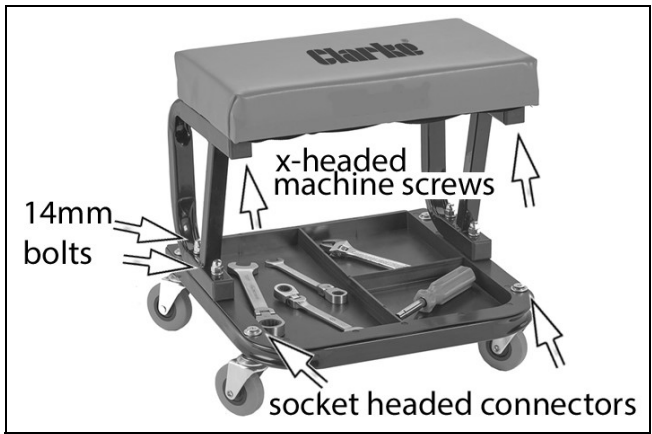

- Fix the castors to the frame using the large washers (7) & retaining inserts (6).

Check that all fixings, including those securing the castors and base frame are tight and secure before using this seat. Your mobile seat is now ready for use.

COMPONENT PARTS OF THE SEAT

No	Description
1	Seat Cushion
2	Side Support
3	Machine Screw
4	Domed Nut
5	Spring Washer
6	Castor Retaining Insert
7	Washer (large)
8	Base Frame
9	Swivel Castor
10	Washer (small)
11	Bolt
12	Plastic Base Tray
FEATURE	RATING
Max Capacity	113 kg
Net Weight	4.35 kg
Dimensions	355 x 375 x 380 mm

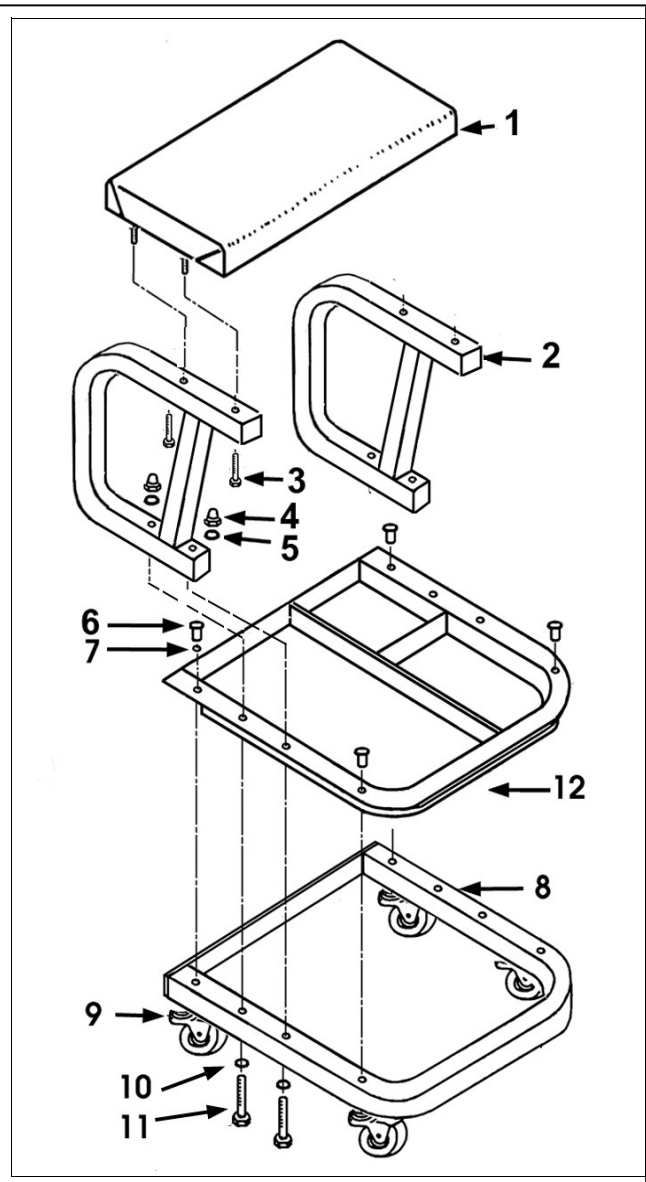

A SELECTION FROM THE VAST RANGE OF

Clarke®

QUALITY PRODUCTS



AIR COMPRESSORS
From DIY to industrial, Plus air tools, spray guns and accessories.

GENERATORS
Prime duty or emergency standby for business, home and leisure.

POWER WASHERS
Hot and cold, electric and engine driven - we have what you need

WELDERS
Mig, Arc, Tig and Spot. From DIY to auto/industrial.

METALWORKING
Drills, grinders and saws for DIY and professional use.

WOODWORKING
Saws, sanders, lathes, mortisers and dust extraction.

HYDRAULICS
Cranes, body repair kits, transmission jacks for all types of workshop use.

WATER PUMPS
Submersible, electric and engine driven for DIY, agriculture and industry.

POWERTOOLS
Angle grinders, cordless drill sets, saws and sanders.

STARTERS/CHARGERS
All sizes for car and commercial use.



PARTS & SERVICE: 0208 988 7400

Parts Enquiries
Parts@clarkeinternational.com

Servicing & Technical Enquiries
Service@clarkeinternational.com

SALES: UK 01992 565333 or Export 00 44 (0)1992 565335

Clarke® INTERNATIONAL Hemnall Street, Epping, Essex CM16 4LG
www.clarkeinternational.com